



ELECTRIC SKILLET WITH MANUAL TILT



SPECIFICATIONS:

Shall be a Solaris Model _____, electrically heated tilting skillet, c-CSA-us and NSF Certified. The skillet shall be of one piece coved corner, 10 gauge stainless steel with a #4 exterior finish and a polished interior. The pan sides shall slope outward to facilitate access to the cooking surface. Heating shall be accomplished by electric elements cast embedded in a full 1-1/2" (38 mm) thick aluminum casting bolted to the underside of the pan for even heat distribution across the entire surface. Pan shall pivot on side trunnions connected to the gear and control consoles. The consoles shall be drip proof, stainless steel clad and shall be supported by an all welded 1-5/8" (41 mm) stainless steel pipe frame with front legs fitted with adjustable bullet feet and rear legs fitted with flange adjustable feet for securing to the floor. The worm and gear tilt mechanism shall allow the pan to tilt forward manually for complete emptying of contents. The controls shall be integrally mounted in the left console and shall include a thermostat, power switch and pilot light. As a safety feature the pan shall be equipped with a high limit thermostat on each element assembly to shut down operation should thermostat fail.

Convenience features shall include a spring assist hinged stainless steel cover with full width handle, no-drip condensate guide, vent port with swing cover and a removable pour strainer on the pour lip.

The skillet shall operate in a temperature range of 160°F to 445°F (71°C to 229°C) with a high temperature safety cut-off at 536°F (280°C).

Model	kW	Capacity	
ETS-30	18	30 gallon	114 litre
ETS-40	27	40 gallon	152 litre

OPERATION SHALL BE BY:

Electric heating elements equipped for operation on:

- 208 VAC, 3 Phase, 50/60 Hz
- 220 VAC, 3 Phase, 50/60 Hz
- 240 VAC, 3 Phase, 50/60 Hz
- 380/220 VAC, 3 Phase, 50/60 Hz.
- 415/240 VAC, 3 Phase, 50/60 Hz.

STANDARD FEATURES

- ✓ Stainless steel cover with spring assist hinges, full width handle, no-drip condensate guide and vent port with swing cover.
- ✓ Elements cast in 1 1/2" (38mm) thick aluminum for uniform and efficient heating.
- ✓ All stainless steel exterior.
- ✓ Pour lip strainer

OPTIONAL ITEMS AT EXTRA COST:

- 380 VAC, 3 Phase, 50/60 Hz
- 415 VAC, 3 Phase, 50/60 Hz
- 480 VAC, 3 Phase, 50/60 Hz.
- 600 VAC, 3 Phase, 60 Hz.
- Etched gallon markings (GMS-30, GMS-40).
- Etched litre markings (LMS-114, LMS-152).
- 2" draw off valve with strainer, front left mounted (TVT-2BP).
- 3" draw off valve with strainer, front left mounted (TVT-3BP).
- 60 minute mechanical timer mounted in left console.
- Casters.
- Correctional package

ACCESSORIES:

- Pan carrier (PC-1).
- Steam pan insert (SPI-30, SPI-40).
- 12" Single pantry faucet with swing spout (SF-12).
- 12" Double pantry faucet with swing spout (DF-12).
- Single pantry faucet and bracket with 60" pot filler (SF-60).
- Double pantry faucet and bracket with 60" pot filler (DF-60).

HEAVY DUTY STEAM





DETAILS AND DIMENSIONS

SERVICE CONNECTIONS

- ⚡ - Electrical connection to be as specified on data plate.
- 💧 - COLD WATER: 3/8" O.D. tubing to faucet (OPTIONAL)
- 🔥 - HOT WATER: 3/8" O.D. tubing to faucet (OPTIONAL)

ELECTRICAL CHARACTERISTICS

MODEL	KW	PHASE	AMPS PER LINE						
			208V	220V	240V	380V	415V	480V	600V
ETS-30	18	3	50.0	47.2	43.3	27.3	25.0	21.6	17.3
ETS-40	27	3	75.0	70.9	65.0	41.0	37.6	32.5	26.0

DIMENSIONS

MODEL	SHIPPING WT.	CAPACITY	UNITS	A	B	C	D	E	F	G
ETS-30	530 lbs. [240 kg]	30 U.S. gal. 114 litres	inches	50 1/2	33 3/4	23 1/8	43 5/8	8 3/4	11	66
			mm	1283	857	587	1108	222	279	1676
ETS-40	642 lbs. [291 kg]	40 U.S. gal. 152 litres	inches	66 1/2	49 1/2	24	59 1/2	8 3/4	11	67
			mm	1689	1257	610	1511	222	279	1702

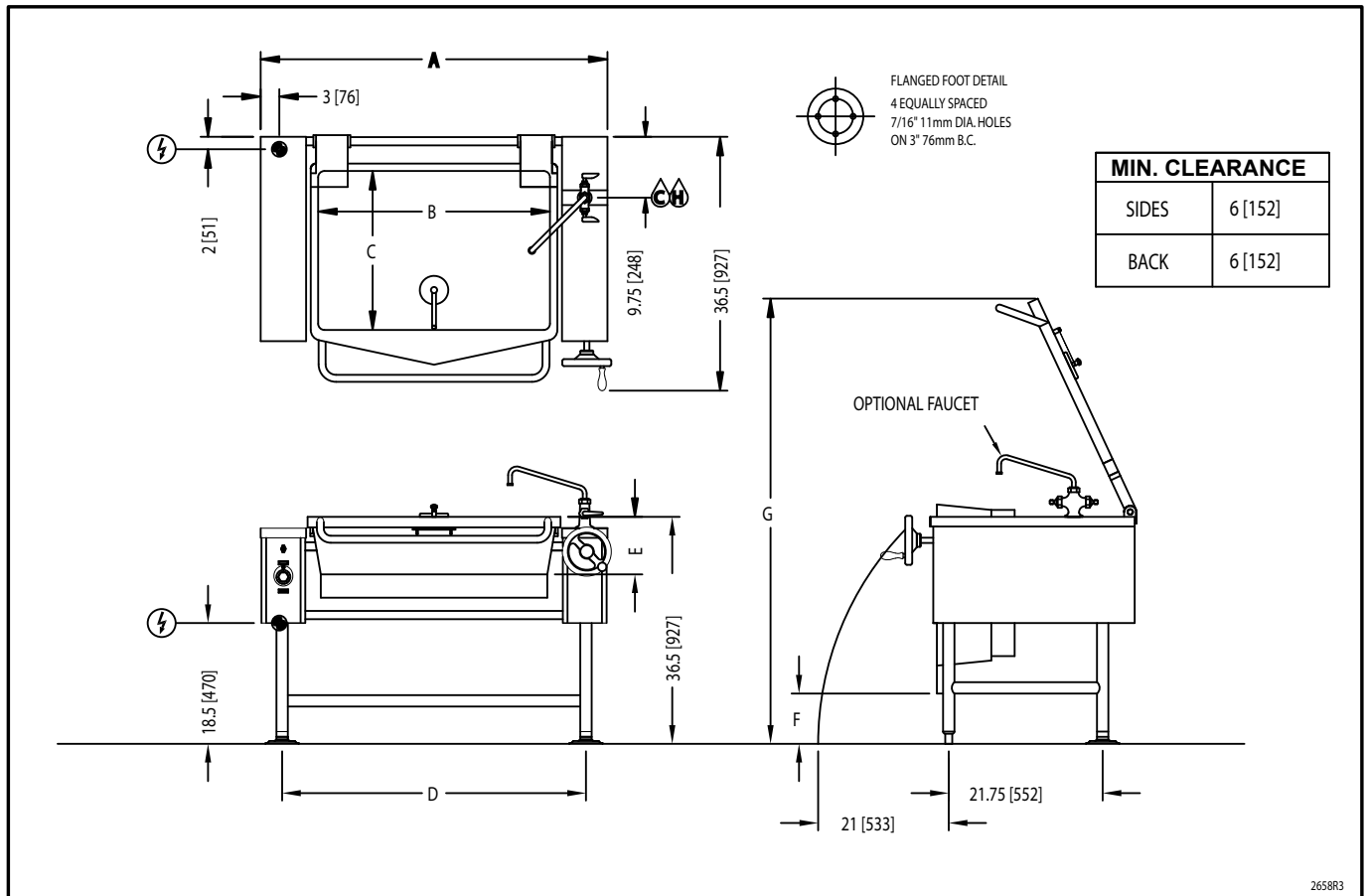

2658R3